

# Wall mount WK-800/24 VST-K

Wall mount with 45° inclination angle  
for UV-Flame detector 800/24 VST-K\*

## General:

Part number (TKZ) : 80883

## Technical data:

Length : 200 mm  
Width : 148 mm  
Height : 197.5 mm  
Material : Stainless steel 1.4301  
Weight : approx. 1 kg



## Drawings:

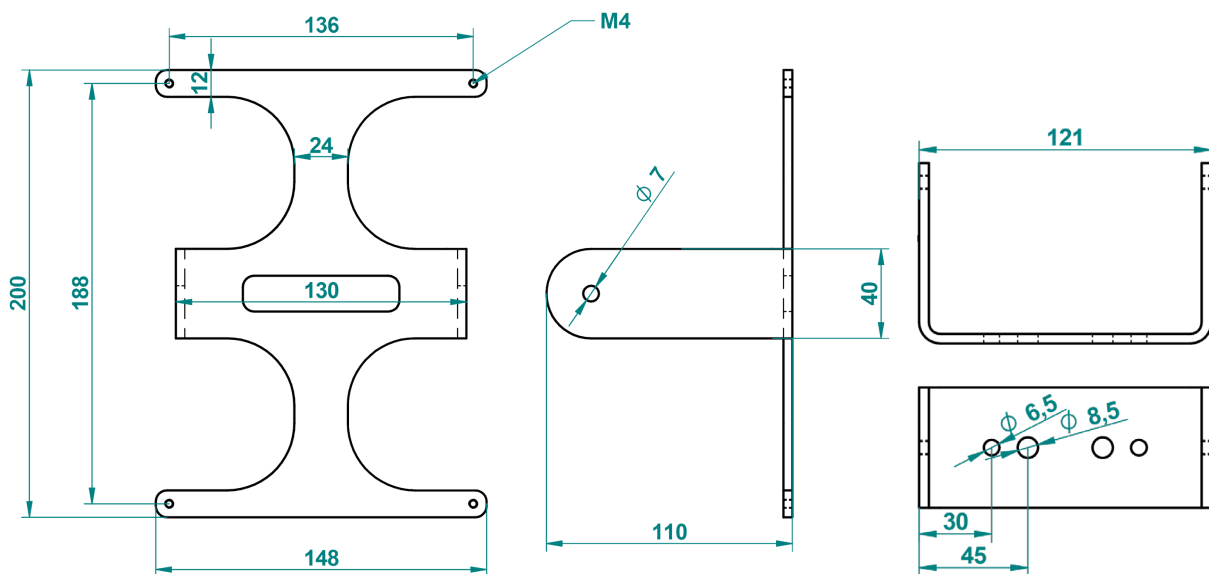

Date  
02.06.2021

Versions-No.:  
0

Datasheet-No.:  
4.21107.5-1

EGON HARIG GmbH  
Gewerbering 4, 22113 Oststeinbek

Tel.: +49 (0) 40 - 713 752 0  
Fax: +49 (0) 40 - 713 752 24

E-Mail: egonharig(at)egonharig.de  
Web: www.egonharig.de